

Aeotec Siren 6.

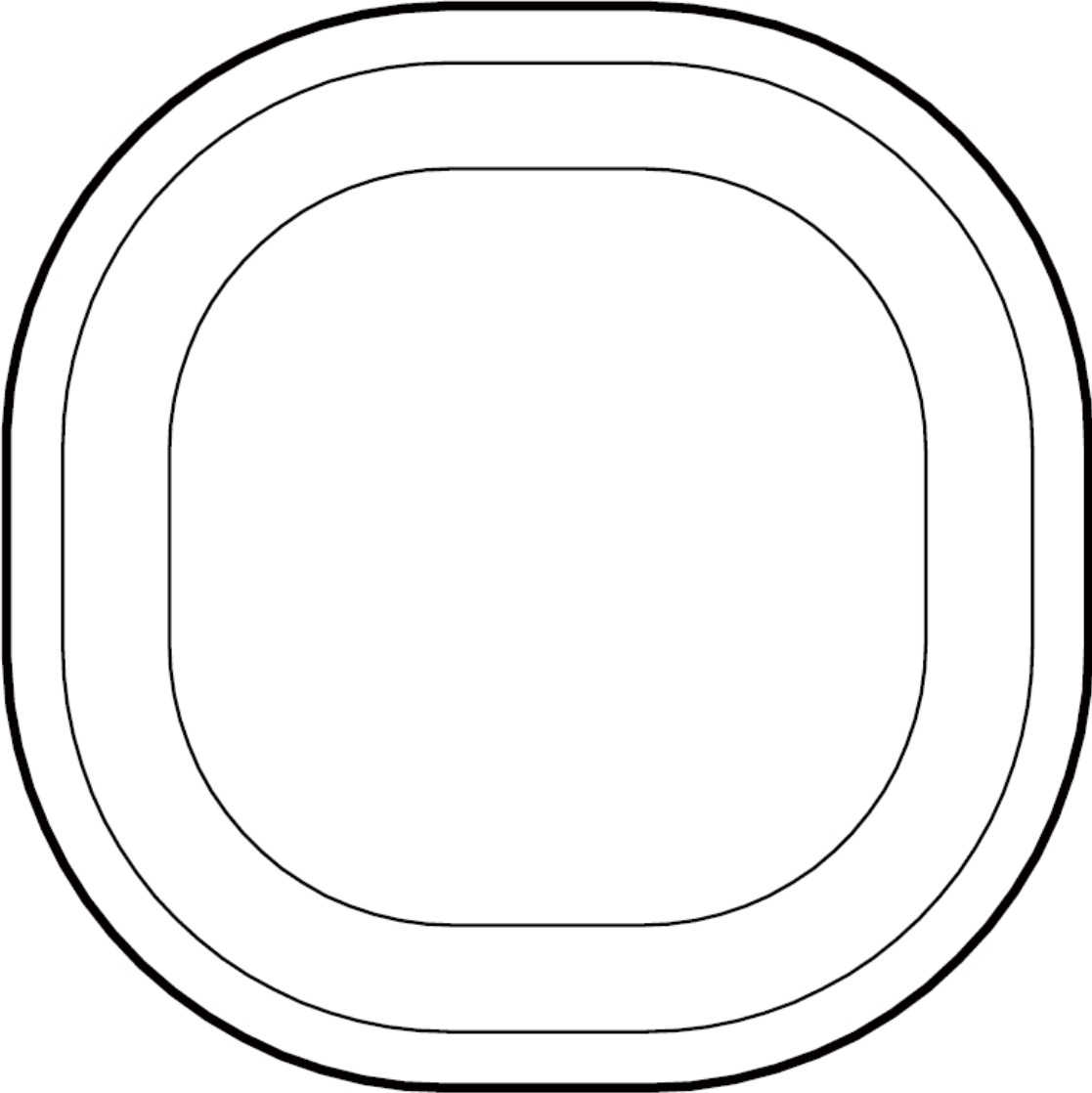

Aeotec Siren 6 was developed to work as a doorbell or siren via Z-Wave Plus. It is powered by Aeotec's Gen5 technology and features Z-Wave S2.

Get to Know your Siren.

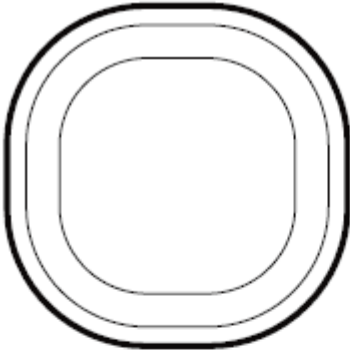

Chime-Front

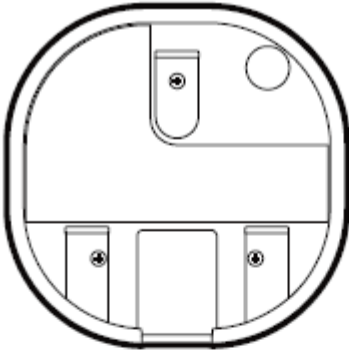

Chime-Back

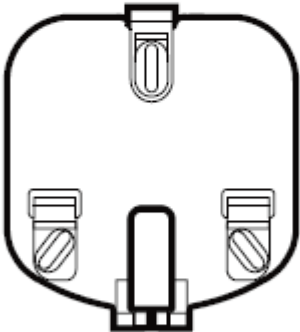

Wall Mount Plate



Double-sided tape



Screws (x 3)

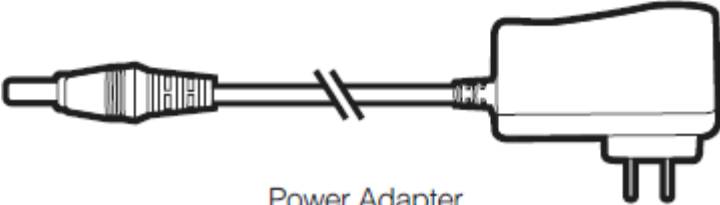

Power Adapter

Pre-loaded Tones.

Tone #	Name	Use
1	Ding Dong	Doorbell
2	Ding Dong Tubular Bell	Doorbell
3	Traditional Apartment Buzzer	Doorbell
4	Electric Apartment Buzzer	Doorbell
5	Westminster Chimes (Hearing Enhanced)	Doorbell
6	Chimes (Hearing Enhanced)	Doorbell
7	Cuckoo (Hearing Enhanced)	Doorbell
8	Traditional Bell	Doorbell

9	Smoke Alarm (Low)	Safety
10	Smoke Alarm (High)	Safety
11	Fire Evacuation Buzzer	Safety
12	CO Alarm	Safety
13	Klaxon	Safety
14	Klaxon (Deep)	Safety
15	Warning Tone	Safety
16	Tornado Siren	Safety
17	Alarm	Security
18	Deep Alarm Tone	Security
19	Alarm (Archangel tone)	Security
20	Alarm (Shrill)	Security
21	Digital Siren	Security
22	Alert Series	Security
23	Security	Misc.
24	Clock Buzzer	Misc.
25	Christmas Tree	Misc.
26	Gong	Misc.
27	Single Bell Ting	Misc.
28	Tonal Pulse	Misc.
29	Upwards Tone	Misc.
30	Door Open	Misc.

Important safety information.

Please read this and other device guides carefully. Failure to follow the recommendations set forth by Aeotec Limited may be dangerous or cause a violation of the law. The manufacturer, importer, distributor, and / or reseller will not be held responsible for any loss or damage resulting from not following any instructions in this guide or in other materials.

Keep product away from open flames and extreme heat. Avoid direct sun light or heat exposure.

Siren 6 is intended for indoor use in dry locations only. Do not use in damp, moist, and / or wet locations.

Warning: to prevent possible hearing damage, test only when wearing appropriate hearing protection.

Quick Start.

Getting your Siren up and running is as simple as plugging it into a wall socket and linking it to your existing Z-Wave network. The following instructions tell you how to link your Siren to your Z-Wave network.

Install Mounting plate in the location of your choice.

1. Affix Siren 6 Wall Mount Plate in any desired location near an outlet.
 - a. Use 3x 20mm screws or double-sided tape.

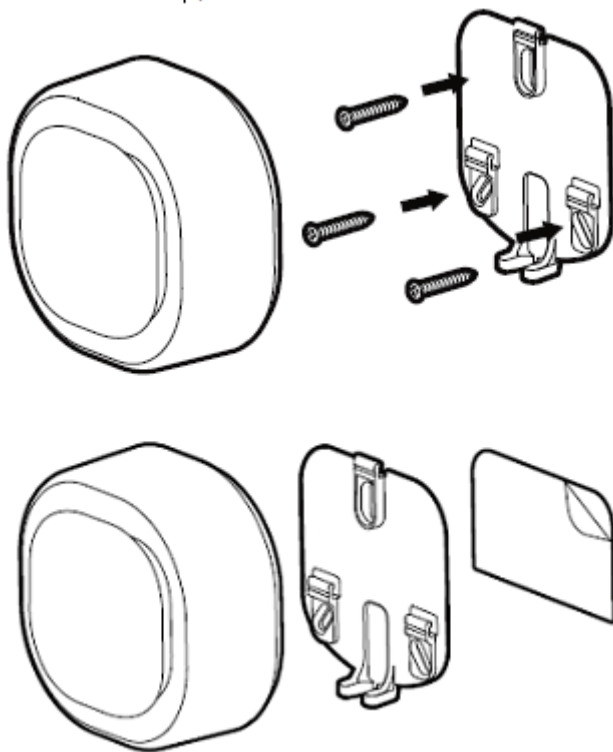

- b. Lock the Siren 6 into place where the mount is installed.

Pairing your Siren 6 into your existing Z-Wave network.

1. Power Siren 6 through the provided power adapter.
2. Ensure that Siren 6 LED is blinking slowly.
3. Set your Z-Wave gateway into pair / add device mode. (Refer to your Z-Wave gateway/controller instruction manual on how to set it into pair mode).
4. Tap the Siren 6 Action Button once (quick). (If your gateway supports S2 encryption, enter the first 5 digits of the DSK into your Z-Wave gateway interface to complete S2 encrypted pairing, DSK is printed on the Siren 6 unit).
5. If Siren 6 has successfully paired to your Z-Wave gateway, the LED on Siren 6 will emit a solid color for 30 seconds, then turn off. If in the case that the Siren 6 failed to pair, LED will continue to blink slowly.

With your Siren now working as a part of your smart home, you'll be able to configure it from your home control software. Please refer to your software's user guide for precise instructions on configuring Siren to your needs.

Advanced.

Removing your Siren from a Z-Wave network.

Your Siren can be removed from your Z-Wave network at any time. It is always advised that you use your gateway to perform an unpair in order to avoid leaving phantom / failed nodes that become difficult to remove. To do so, follow the steps below:

1. Place your gateway or controller into Z-Wave unpair or exclusion mode. (Please refer to your controller/gateway manual on how to do this)
2. Press the Action Button 6x times in 2 seconds on your Siren.
3. If your Siren has been successfully unpaired from your network, its LED will begin to blink slowly which indicates that it is ready to be paired again.

Test Siren 6 sound manually.

You will be able to manually test your Siren 6 unpaired or paired to a Z-Wave network, to determine if its sound is working, perform the button action listed below:

- Press and hold Action Button down for 2-5 seconds

Safety: Test only when wearing necessary ear protection. Siren 6's speaker emits tones up to 105dB that can cause hearing damage.

Reset your Siren.

This method is not fully advised unless your gateway has failed, and you do not yet have another gateway to perform a general unpair on Siren 6.

To do this, follow the steps below:

1. Press and hold the Action button for 20 seconds
2. [2-5 seconds], the test siren sound will run, then stop after 5 seconds has passed.
3. [5-20 seconds] The LED will continue to blink faster (5 to 10 seconds) and faster (10 to 20 seconds).
4. [21 seconds and later] The LED will then quickly flash 3 times then will have LED breath in and out as you hold down the Action Button
5. Release the Action button, and the Siren 6 will factory reset.

Low battery indicator for Button #1 - #3)

Siren 6 has 3 low battery indicators for 3 possible button slots. This will indicate if battery is low on any connected button to Siren 6.

Button 1

- LED blinks once (100ms), then no LED for 5 seconds. Repeats continuously until replacement of battery.

Button 2

- LED blinks twice (100ms), then no LED for 5 seconds. Repeats continuously until replacement of battery.

Button 3

- LED blinks thrice (100ms), then no LED for 5 seconds. Repeats continuously until replacement of battery.

To resolve the LED from blinking, you must replace the battery of your Button that is connected to Siren 6.

1. Remove the battery of Button (based on the LED indicator above).
2. Wait 10-20 seconds, allow the button to power cycle
3. Replace with a new battery
4. Tap the button once to update the battery level on Siren 6 / Doorbell 6

Upgrade Siren 6 to Doorbell 6.

You can upgrade Siren 6 to Doorbell 6 at any time, all you need is Aeotec Button which is a wireless add-on button used for Siren/Doorbell 6. Siren 6/Doorbell 6 supports up to 3 Aeotec Buttons.

You can learn how to pair Aeotec Button to Siren 6 in the Button manual.

Siren 6 technical specifications.

Name: Siren 6

Model Number: ZW164

Product Dimensions: 76 x 76 x 38.5 mm

Package Dimensions: 105 x 164 x 55 mm

Product Weight: 204 g

Total Package Weight: 275 g

UPC/EAN:

US: 810667024154

EU: 1220000016224

UK: 1220000016477

AU: 1220000016217

Wireless Technology: Z-Wave, 433.92 FSK.

Repeater: Yes

Beaming: Yes

Z-Wave Plus: Yes

Z-Wave Security: S0, S2 unauthenticated, and S2 Authenticated

Z-Wave Hardware: ZM5101

Z-Wave Library Type: Enhanced 232 Slave

Z-Wave Device Type: Sound Switch

Z-Wave Role Type: Always On Slave.

Smart Start Compatible: No

Input Voltage:

Adapter: 5V/2A

Battery: 3.7V

Backup Battery:

PT502035

400mAh

Not Detachable

Rechargeable via power adapter

4 Hours total use.

Storage: 16M

Sensors: Vibration

Max Supported Tones: 30

Max Supported Buttons: 3

Max Standby Power: 0.7W.

Max Volume: 105dB from 5cm

Operating humidity: 8% to 80%.

Operating temperature:

0°C to 40°C

32°F to 104°F.

Operating Distance:

30m indoor

150m outdoor

Specifications subject to change without notice due to continuing product improvement.